



Designation: F2436 – 14 (Reapproved 2019)

Standard Test Method for Measuring the Performance of Synthetic Rope Rescue Belay Systems Using a Drop Test¹

This standard is issued under the fixed designation F2436; the number immediately following the designation indicates the year of original adoption or, in the case of revision, the year of last revision. A number in parentheses indicates the year of last reapproval. A superscript epsilon (ϵ) indicates an editorial change since the last revision or reapproval.

1. Scope

1.1 This test method covers drop test procedures to measure rope rescue belay system performance. It applies only to belay systems consisting of an untensioned rope connecting the load to an anchored belay device. This test method does not address other types of belays, such as self-belays or belays for lead climbing, nor does it test the rescuer's belaying ability.

1.2 This test method may be used to help measure a rescue belay system's performance under controlled drop test conditions, but it will not necessarily provide guidance as to which belay method is most suited to a particular application. Other considerations, such as ease of handling, performance on different types and diameters of rope, portability, versatility, system safety factor, cost, and automatic operation that do not require the positive action of the belayer may influence the selection of a belay system and are not dealt with in this test method. See [X1.1](#).

1.3 The values stated in SI units are to be regarded as standard.

1.4 *This standard may involve hazardous materials, operations, and equipment. This standard does not purport to address all of the safety concerns associated with its use. It is the responsibility of whoever uses this standard to consult and establish appropriate safety, health, and environmental practices and determine the applicability of regulatory limitations prior to use.* Additional precautions for this test method are given in [8.1](#) and [8.2](#).

1.5 *This international standard was developed in accordance with internationally recognized principles on standardization established in the Decision on Principles for the Development of International Standards, Guides and Recommendations issued by the World Trade Organization Technical Barriers to Trade (TBT) Committee.*

¹ This test method is under the jurisdiction of ASTM Committee [F32](#) on Search and Rescue and is the direct responsibility of Subcommittee [F32.01](#) on Equipment, Testing, and Maintenance.

Current edition approved April 1, 2019. Published April 2019. Originally approved in 2005. Last previous edition approved in 2014 as F2436 – 14. DOI: 10.1520/F2436-14R19.

2. Referenced Documents

2.1 *ASTM Standards:*²

[D1776 Practice for Conditioning and Testing Textiles](#)
[F2266 Specification for Masses Used in Testing Rescue Systems and Components](#)

2.2 *Other Document:*

[CI 1801-98 Low Stretch and Static Kernmantle Life Safety Rope](#)³

3. Terminology

3.1 *Definitions:*

3.1.1 *belay, n*—a secondary system, or the system components, used to arrest the load in the event of a failure in the system.

3.1.2 *belay, v*—*in rope rescue systems*, to operate an untensioned secondary rope (belay line) so that it may be taken in or let out as the load is raised or lowered, and then hold the load in case of failure of the lifting line (working line) system.

3.1.3 *belay assembly, n*—all elements of the belay system, but not including the belay line and the belay anchor.

3.1.4 *belay assembly extension, L, (cm), n*—the increase in length of the belay assembly, due to stretch or other extension, measured from the anchorage to the farthest gripping point of the belay assembly while statically tensioned, post-drop, expressed in centimetres (cm).

3.1.5 *belay device, n*—that element of the belay system providing a moveable connection point to the belay line, which can secure the belay line when necessary.

3.1.6 *belay line, n*—*in rope rescue systems*, a secondary line, generally untensioned, acting as a back-up to the lifting line as distinguished from the lifting line (working line) that actually raises, lowers, or transports the load.

3.1.7 *belay system, n*—the belay assembly and the belay line, but for the purposes of this test method, not including the belay anchor.

² For referenced ASTM standards, visit the ASTM website, www.astm.org, or contact ASTM Customer Service at service@astm.org. For *Annual Book of ASTM Standards* volume information, refer to the standard's Document Summary page on the ASTM website.

³ Available from Cordage Institute, 994 Old Eagle School Rd., Wayne, PA 19087, <http://www.ropecord.com>.

3.1.8 *belay system extension*, L , (cm), n —the distance below the zero line (this excludes drop height) reached at the maximum extension during fall arrest, prior to rebound; also known as stopping distance, expressed in centimetres (cm).

3.1.9 *belay system failure*, n —when the test block hits the ground.

3.1.10 *drop height*, L , (cm), n —the free-fall distance the block falls before the belay system begins to arrest its fall.

3.1.11 *elongation classification*, n —in rope rescue systems, elongation of new rope as measured by CI 1801-98 at 10 % of the manufacturer’s rated breaking strength: static <6 % elongation, low-stretch >6 % and <10 % elongation

3.1.12 *extension*, L , n —the change in length of a material, device, or system due to a change in an applied force, usually measured at some specified force, force rate, or duration of force, or combination thereof.

3.1.13 *final rope length*, $[L]$, (cm), n —the distance between the inside of the bowline where it contacts the shackle of the test block and the lowest gripping portion of the belay assembly after the test block has rebounded and come to rest.

3.1.14 *lifting line*, n —the line that lifts the test block and from which a quick disconnection is made to drop the test block (working line).

3.1.15 *maximum arrest force*, MAF , (N), n —the peak force measured during the fall arrest.

3.1.16 *pre-grip slippage*, L , (cm), n —rope movement through the belay device before gripping stops movement.

3.1.17 *rope rescue system*, n —a system using fiber ropes to raise, lower, or transport a load.

3.1.18 *zero line*, n —the level of the contact between the inside of the bowline and test block shackle when it is 3 m below the lowest gripping portion of the belay assembly, prior to the drop.

4. Summary of Test Method

4.1 A rigid test block of the correct mass simulates a rescue load. A rope of given length connects the test block to a belay assembly that is in turn connected to a suitably rigid overhead anchor point. The test block is raised a given distance with a separate lifting system and is then released. After the block has free-fallen to its starting point, the belay system (the rope and belay assembly) begins to arrest its fall. Among other things, maximum arrest force and belay system extension are measured. The belay system may or may not be successful in stopping the falling test block.

5. Significance and Use

5.1 The types of rope rescue systems to which this test method apply use a tensioned mainline and untensioned belay line. If a fall occurs because of a mainline system failure or misuse, considerable energy must be absorbed by the belay for a successful arrest. This drop test method simulates a “worst case” condition when systems are operated as designed, and is designed to help evaluate and compare the performance of various rope rescue belay systems under such conditions. (See

Note 1.) The successful catching of a load does not imply that the tested system is suitable for any and all belaying. See **X1.2**.

NOTE 1—Higher forces may be encountered under some circumstances, such as the belay being operated with excessive slack.

6. Interferences

6.1 The method used to release the test block could affect the results by imparting motion to the block, in addition to the straight fall caused by gravity.

6.1.1 Residual magnetism of an electromagnetic release shall be guarded against.

6.1.2 The use of a light cord between the test block and the hoist line, which is cut by a heated nichrome wire or stick mounted knife, is also satisfactory.

6.1.3 Any release buckle, latch, or device that might impart a sideways force to the suspended mass shall not be used.

6.1.4 Any restriction imposed on the test block, such as the use of guide rails to contain and control the block’s fall, or the use of a linear motion transducer, shall be constructed and maintained so that the combined effect shall not reduce the velocity of the mass more than 2 % from the velocity of a free falling block of similar mass. Velocity measurements shall be made and recorded at the beginning of each test day when guide rail type test rigs are to be used.

6.2 If the lifting line’s system uses a twisted cable, there may be difficulties with the test block turning and twisting the rope. This can be prevented by light “anti-twister” cords running off to the side of the block that are released at the same time as the lifting line connection.

6.3 Inconsistency in the tightening of knots shall be avoided.

7. Apparatus

7.1 The test facility shall be a structure with less than 1 mm of immediate elastic deformation at a force of 50 kN at the anchor point and having a natural frequency above 200 Hz.

7.1.1 Failing this, a distinct cautionary note should be made in all reports generated at the test facility regarding the anchor rigidity or natural frequency.

7.2 The test block shall have an appropriate mass and, if made from a collection of plates, bars, or ingots, shall be joined in a fashion that prevents play or relative movement of parts during the testing. It shall be provided with a shackle for the attachment of the belay line and the lifting line (through the quick-disconnect fitting) from which it hangs in symmetry. The shackle shall have less than 1 mm of immediate elastic deformation at a force of 50 kN.

7.2.1 The mass of the rigid test block shall be Type II (100 kg), Type IV (200 kg), or Type V (280 kg) ± 1 %, including attachment hardware, for the testing of equipment intended for use with various rescue systems, in accordance with Specification **F2266**. The user should select the most appropriate mass to the intended application. Adequate attachment point, rigidity, and symmetry shall be maintained. The mass used shall be included in the report.

7.3 The belay line shall be tied directly to the test block using a bowline knot. Use of a setup where the rope is tied to

a platen (catch plate) upon which the falling test block impacts shall not be permitted.

7.4 The test block lifting system shall be able to position the test block to a tolerance of ± 0.5 cm and when stopped, sustain the test block for a 5 min period at a given height with the same tolerance.

7.4.1 The lifting line shall pass not more than 10 cm horizontally in distance from the anchor point for the belay assembly.

7.5 If a pit of loose material such as sand is used, care should be taken so that the test block does not increase its mass by picking up material from the pit after impact.

7.6 For belay assemblies that require an active gripping hand for operation, an artificial hand shall be substituted to prevent staff injuries.

7.6.1 The artificial hand shall be constructed as pictured in Fig. 1.

7.6.2 The artificial hand shall be spring pressure plates that provide a constant belay rope tension. The user shall select the appropriate tension. See X1.3. The tension used shall be included in the report.

7.6.3 When an artificial hand is used, it is considered to be an integral part of the belay assembly.

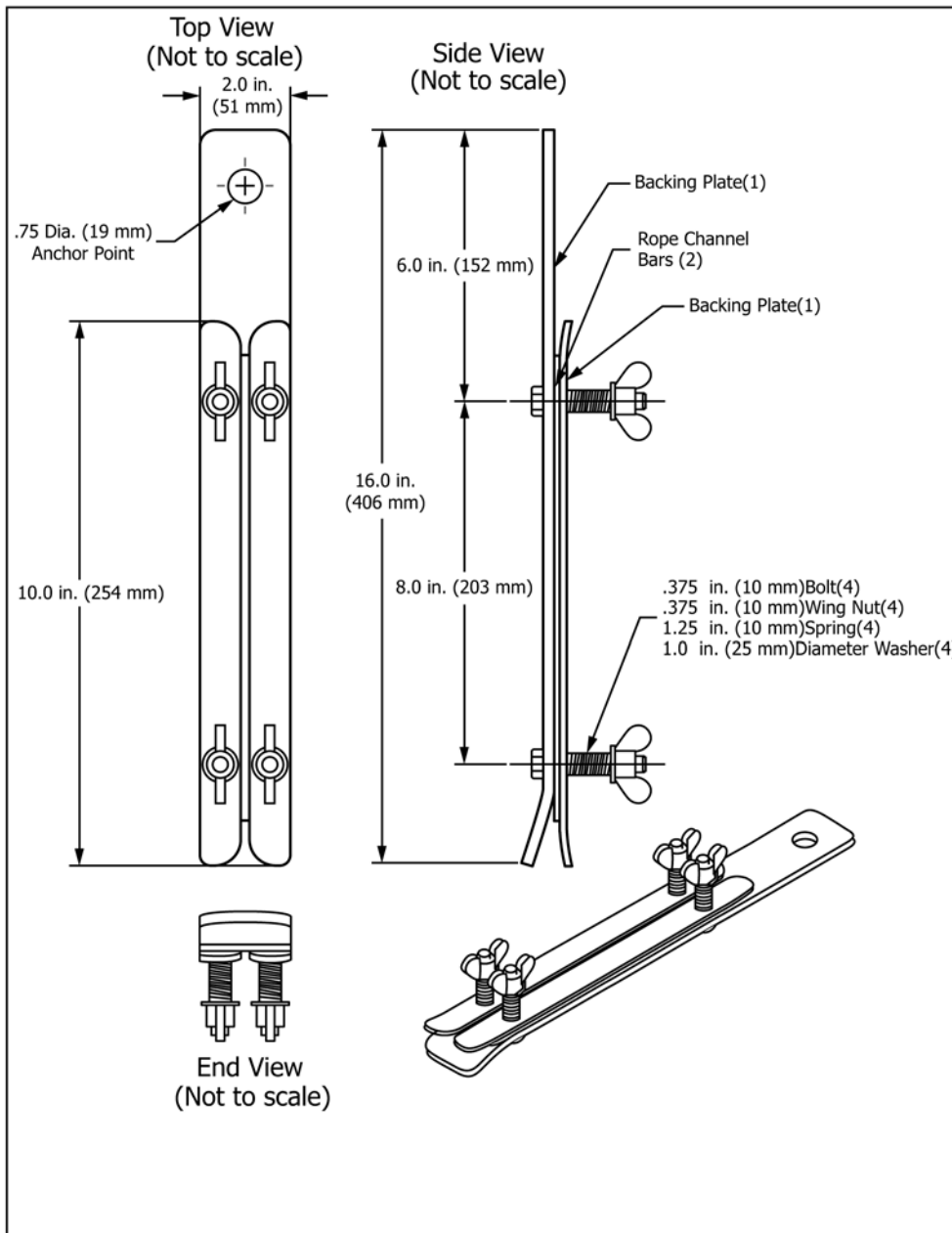

FIG. 1 Artificial Hand